

INSTRUCTION MANUAL
FOR
DIGITAL BLOOD PRESSURE MONITOR

REF **CH-456**

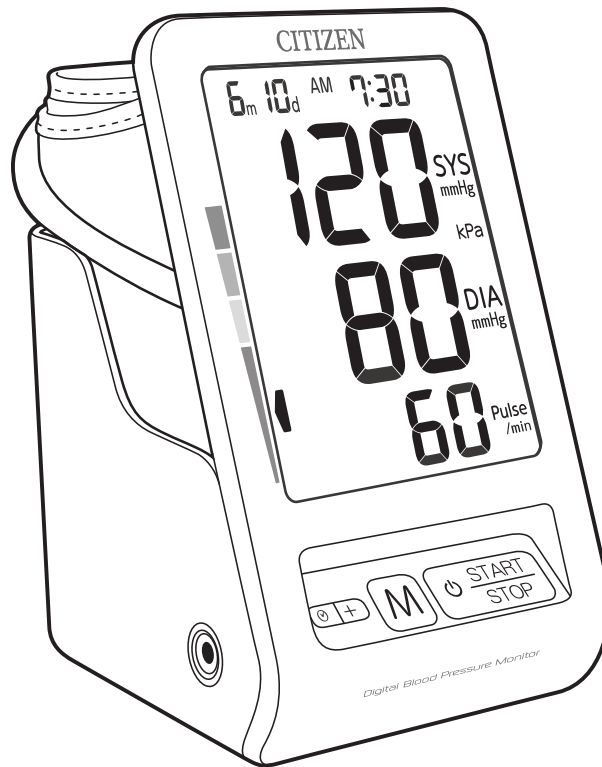

English

Español

Français

Русский

한국어

العربية



* Please read all of the information in the instruction manual before operating the monitor.

Contents

- 1 - GENERAL REMARKS
- 3 - PRECAUTIONS FOR USE AND MAINTENANCE
- 6 - IDENTIFICATION OF PARTS
- 7 - LOADING THE BATTERIES
- 7 - REMOVING THE BATTERIES
- 8 - USING AC ADAPTER (OPTION)
- 9 - TIME ADJUSTMENT
- 10 - MEASURING YOUR BLOOD PRESSURE
- 13 - TIPS FOR OBTAINING ACCURATE MEASUREMENTS
- 14 - CALLING UP THE DATA STORED IN MEMORY
- 15 - ABOUT "BLOOD PRESSURE"
- 16 - BLOOD PRESSURE Q&A
- 16 - KEY TO DISPLAY ICONS
- 17 - BEFORE REQUESTING REPAIRS OR TESTING
- 18 - SPECIFICATIONS

■ **Ensure that you have all the following components.**

- Blood pressure monitor unit • Instruction Manual
- 4 AA-size batteries (for monitor)
- Cuff (model: SCN-003)

[OPTION]

- Large Cuff (model: SCL-005) • AC Adapter (model: AC-230CZ)

GENERAL REMARKS

General remarks on blood pressure and blood pressure measurement

1. To deflate the cuff quickly, press the "START/STOP" switch.
2. Before applying your blood pressure cuff, be sure you have selected the appropriate size cuff:
Cuff (model: SCN-003) fits arm circumference: 22-32cm
[OPTION]
Large Cuff (model: SCL-005) fits arm circumference: 32-42cm
3. When attaching the cuff, adjust the position of the cuff so that the blue marker is located in the center of your arm and the hem of the cuff is 1-2 cm for Cuff / 2-3 cm for Large Cuff above your elbow.
4. Self measurement is not therapy! In no event should you change the dosage of your medication prescribed by your physician.
5. As preparation for measuring your blood pressure, you should urinate and then remain relatively still for 10 to 15 minutes prior to measurement.
6. DO NOT place too much emphasis on the results of one measurement. Keep a continuing record of your blood pressure variations. A complete picture can only be obtained from a large number of readings.

To obtain correct blood pressure measurements

1. Take five or six deep breaths and then relax before measuring your blood pressure. If you are tense when taking the measurement, you will not get a valid reading.
2. Your blood pressure will be elevated if you are anxious or irritated, suffering from lack of sleep or constipation, or have just taken some exercise or eaten a meal.

3. Wrap the cuff around your arm and tighten it so that one finger can be inserted between the cuff and arm. (👉 See page 10, 11)
4. DO NOT measure your blood pressure after bathing or drinking.
5. Measure your blood pressure where the room temperature is around 20°C. DO NOT measure your blood pressure when it is too cold (below 10°C) or too hot (above 40°C) in the room.
6. DO NOT try to measure your blood pressure immediately after drinking coffee or tea or after smoking.
7. Measure your blood pressure when you are relaxed and still. Keep the center of the cuff at the level of your heart and DO NOT move your arm or talk.
8. DO NOT measure blood pressure when the cuff has been on your arm for a few minutes or more. During this time, your arm will have built up a higher blood pressure and you will not get valid reading.
9. If the Body Movement Indicator or Irregular Heartbeat (IHB) Indicator is displayed, relax and measure your blood pressure again. If the Irregular Heartbeat (IHB) Indicator appears frequently, you are advised to consult a doctor about your health condition.
(👉 See page 12)
10. The figure below shows the blood pressure classifications under the WHO standards.

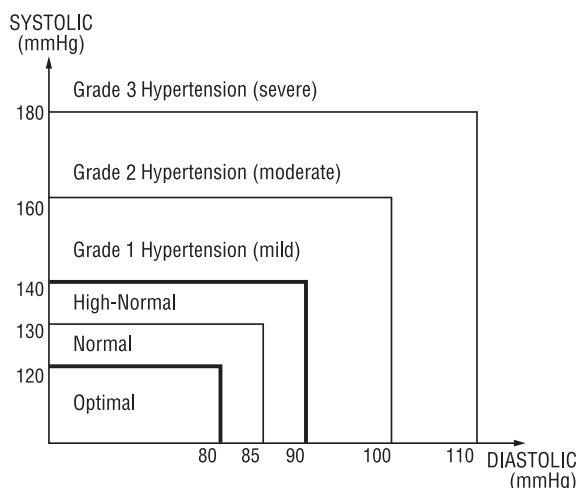

Remarks:

The graph is not exact, but may be used as a guide in understanding non-invasive blood pressure measurements. The device is only intended for use by adults.

Definitions and Classifications of Blood Pressure Levels

* This unit is equipped an indicator which visually indicates the blood pressure classification (Optimal/Normal/High-Normal/Grade 1 Hypertension/Grade 2 Hypertension/Grade 3 Hypertension) of the result after each measurement.

11. Intended Use

- This device is noninvasive blood pressure monitor by oscillometric method. This device can measure the systolic blood pressure (SYS), the diastolic blood pressure (DIA) and the pulse rate automatically.
- This device is intended to be used for checking personal health condition at home under the direction of a physician and is not intended to be a diagnostic device.
- This device is not intended for use with neonates or infant, and not intended for automatic cycling measurement.

Measure your blood pressure at the same time each day.

* Your blood pressure changes all the time. This means that data gathered over a long period has far more significance than data from just one measurement. For this reason, you must measure your blood pressure on a daily basis. Ideally, you should measure your blood pressure at the same time each day, wherever possible.

PRECAUTIONS FOR USE AND MAINTENANCE

Precautions for use









1. If you suffer from heart disease, high blood pressure or other circulatory disease, consult your physician before using the monitor.
2. Inflating to a higher pressure may result in bruising where the cuff is applied. If the cuff pressure feels abnormal or you experience any other irregularity while using the cuff, reduce the pressure immediately by pressing the “START/STOP” switch, detach the cuff or unplug the air hose connector from the monitor and then consult the sales outlet where you purchased the monitor.
3. If you think the measurement is abnormal or if measurement makes you feel unwell, discontinue use and consult your physician.
4. Blood pressure measurement may not be possible for anyone with a weak pulse or arrhythmia.
5. Repeated blood pressure measurement and prolonged overinflation may cause problems such as congestion or swelling in some people.
6. Frequently repeated blood pressure measurements will not give accurate results. Allow an interval of about 1 minute between measurements.
7. If you suffer from a severe problem with blood circulation in your arms, consult your physician before using the monitor. Failure to do so could be hazardous to your health.
8. Measurement may not be possible for anyone with insufficient blood flow to the area where measurements will be taken or who suffers from a frequent irregular heartbeat. Consult your physician for advice on whether to use the monitor.
9. DO NOT wrap the cuff around an injured arm.
10. DO NOT wrap the cuff around an arm in which a drip (intravenous infusion) is inserted or which is being used for blood transfusion as part of medical treatment. Doing so could result in an injury or a serious accident.
11. Do not share the cuff with other infective person to avoid cross-infection.
12. If you have any doubt about the application of the cuff on the arm on the side of a mastectomy, consult your physician.
13. DO NOT use the monitor in the vicinity of flammable gases such as those used for anaesthesia. Doing so could ignite the gases and cause an explosion.
14. DO NOT use the monitor in enriched oxygen environments such as a hospital’s hyperbaric chamber or oxygen tent. Doing so could ignite the oxygen and cause a fire.
15. DO NOT use mobile phones near the monitor as this could result in a malfunction.
16. If you use a cardiac pacemaker, consult your physician before using the monitor.
17. Be sure to use this unit only for measuring blood pressure. DO NOT use it for any other purpose.
18. Be sure to use only our authorized parts and accessories. Parts and accessories not approved for use with the device may damage the unit.
19. DO NOT use this unit on infants.
20. Blood pressure measurement may not be possible for anyone with common arrhythmias such as atrial or ventricular premature beats or atrial fibrillation.

Maintenance Precautions

1. DO NOT store the blood pressure monitor in locations exposed to direct sunlight, high temperatures (over 60°C), low temperatures (below -20°C), high relative humidity (over 95%) or excessive amounts of dust. Make sure to store the blood pressure monitor, where children, pets and or pests are not there.
2. DO NOT drop the blood pressure monitor or the cuff and subject it to other shocks or vibration.
3. Remove the batteries if the monitor will be left unused for a long period.
4. DO NOT attempt to disassemble the monitor or the cuff.
5. DO NOT bend the cuff or the air hose excessively.
6. If the monitor and the cuff are very dirty, wipe them clean with a cloth moistened with a neutral detergent. Then wipe them with a dry cloth.
7. NEVER clean the blood pressure monitor with alcohol, thinners or benzene, as this could damage the monitor.
8. To clean the cuff, wipe it with a moist cloth. Avoid hard rubbing, as this will cause air leakages. Take care also not to get water into the air hose.

 Warning	No modification of this device is allowed.
--	--

Symbols Explanation

-  ₀₀₈₆ : The CE marking is meant to provide information to market inspectors in the EU member countries.
-  : Type BF applied part (The cuff is type BF applied part.)
-  : Keep dry
-  : Warning
-  : Refer to instruction manual before use
-  : Appliance compliance WEEE directive
-  : Accumulators and battery packs for separate collection
-  : Manufacturer

 Warning	The device has been tested and homologated in accordance with EN60601-1-2 for EMC. This does not guarantee in any way that the device will not be affected by electromagnetic interference. Avoid using the device in high electromagnetic environment.
--	---

Nature and frequency of maintenance:

This product is designed for use over an extended period of time; however, it is generally recommended that it be inspected every two years to ensure proper function and performance.

Protect the nature environment:

Please help to protect natural environment by respecting national and/or local recycling regulations when disposing of the battery and the product at the end of their useful life.

WEEE MARK

If you want to dispose this product, do not mix with general household waste. There is a separate collection systems for used electronics products in accordance with legislation under the WEEE Directive (Directive 2002/96/EC) and is effective only within European Union.

**Information for Users on Collection and Disposal of used Batteries.**

The symbol in this information sheet means that used batteries should not be mixed with general household waste.

For proper treatment, recovery and recycling of used batteries, please take them to applicable collection points.

For more information about collection and recycling of batteries, please contact your local municipality, your waste disposal service or the point of sale where you purchased the items.

**Information on Disposal in other Countries outside the European Union.**

This symbol is only valid in the European Union.

If you wish to discard used batteries, please contact your local authorities or dealer and ask for the correct method of disposal.

Note for the battery symbol.

The symbol might be used in combination with a chemical symbol. In this case it complies with the requirement set by the Directive for the chemical involved.

Reference European standard:

The blood pressure measuring device corresponds to regulation EN60601-1, EN1060-1, EN1060-3, EN1060-4.

Calibration:

The blood pressure measuring device is generally recommended to have the monitor inspected every two years to ensure correct functioning and accuracy. Please contact a distributor.



Name : CITIZEN SYSTEMS JAPAN CO., LTD.
Address : 6-1-12, Tanashi-cho, Nishi-Tokyo-shi,
Tokyo 188-8511, Japan

European Representative:

Name : WvW elektronische Geräte Vertrieb GmbH
Address : Fintelmanstraße 20/Eingang, Martin-Heydert-Straße,
D-14109 Berlin, Germany



- For technical data, please contact our European Representative

IDENTIFICATION OF PARTS

Component names

<Main Unit>

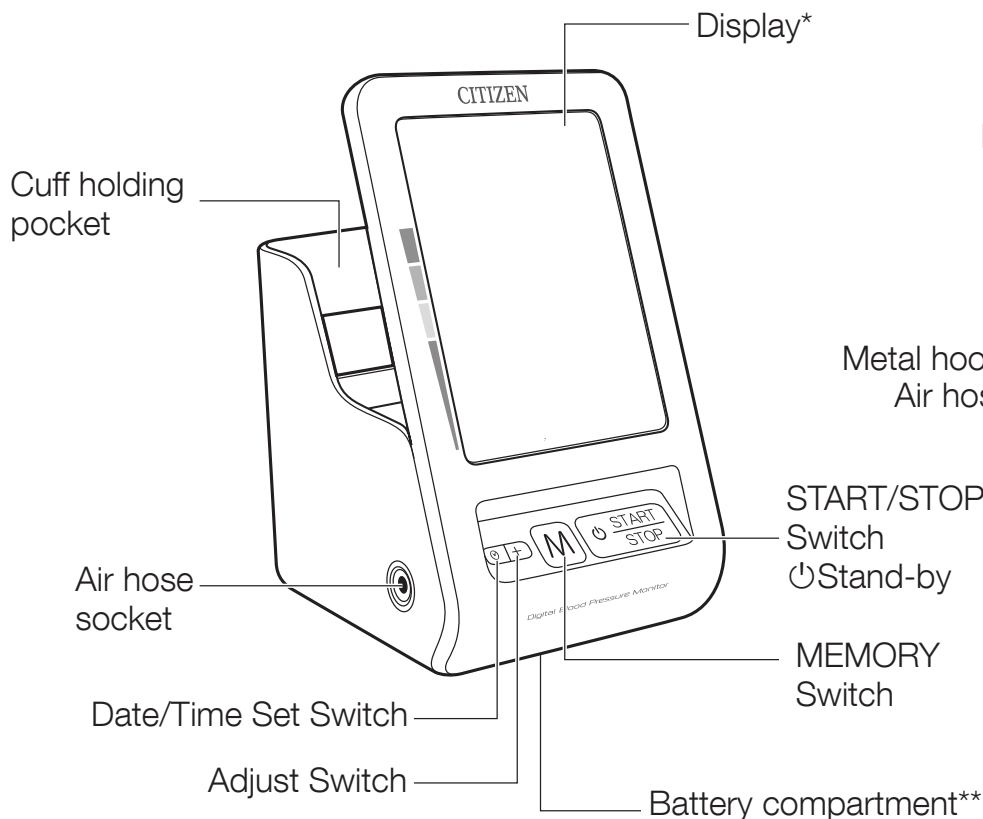

<Cuff>

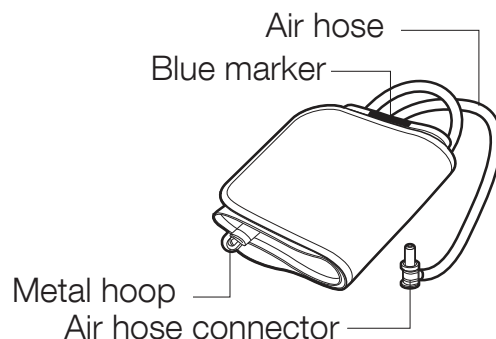

*See page 6 for the display icons.

**See page 7 for the Battery compartment

<Display>

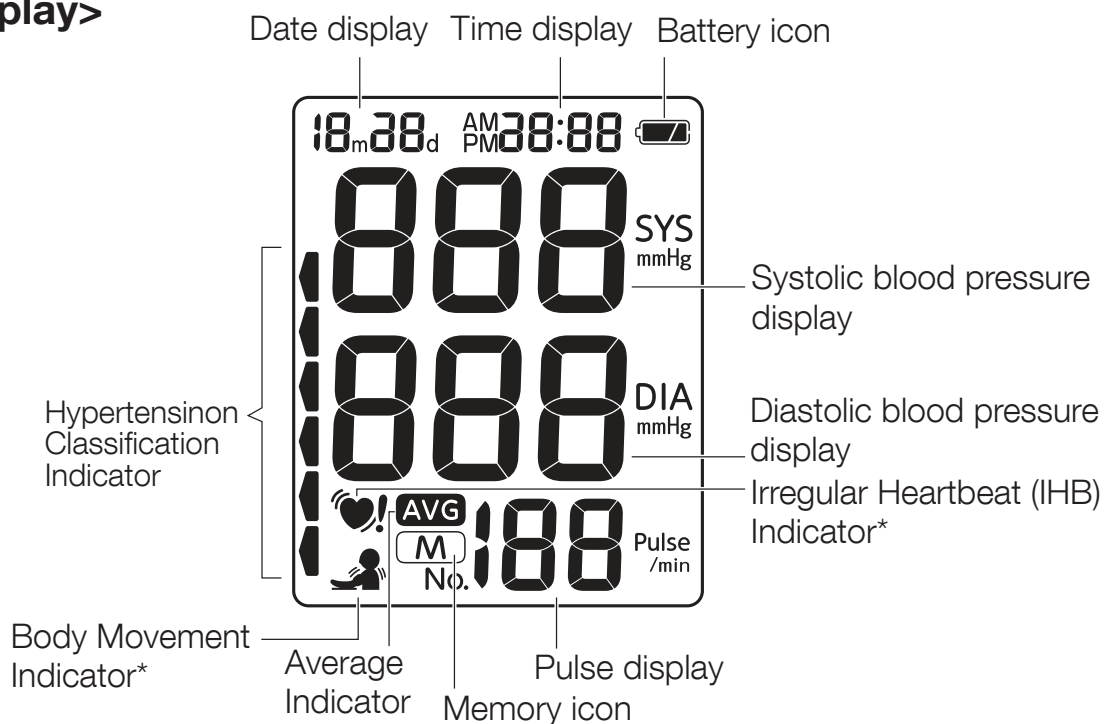

* See page 12 for the Body Movement Indicator and Irregular Heartbeat (IHB) Indicator.

LOADING THE BATTERIES

(Batteries supplied with the unit should be loaded in compartment before you use the blood pressure monitor.)

- * When you install the batteries for the first time after purchase, the monitor will display the clock setting screen. Follow step 2 and subsequent steps in TIME ADJUSTMENT ( See page 9) to set the clock.

1 Open the cover of battery compartment.

Pressing the hook down, pull the cover toward you to open.

- * If the Blood pressure monitor is left unused for an extended period of time, the batteries should be removed from the compartment.

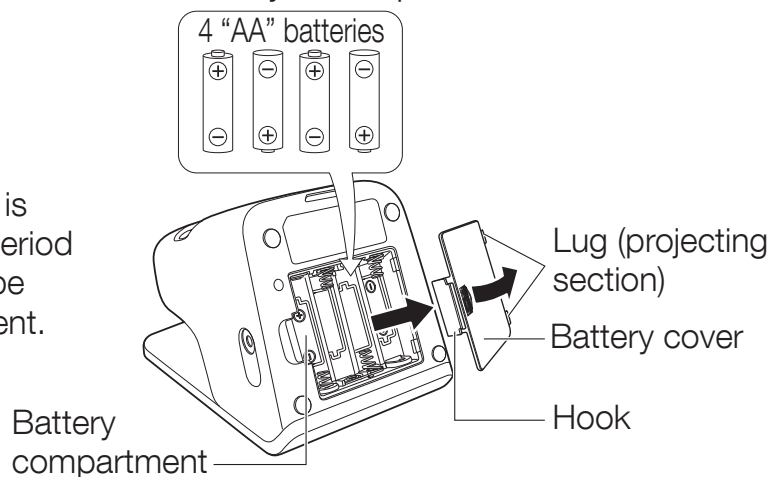

2 Place batteries in the compartment.



Put the batteries paying attention to the positive and negative terminal symbols ⊕ and ⊖.

3 Close the battery cover.

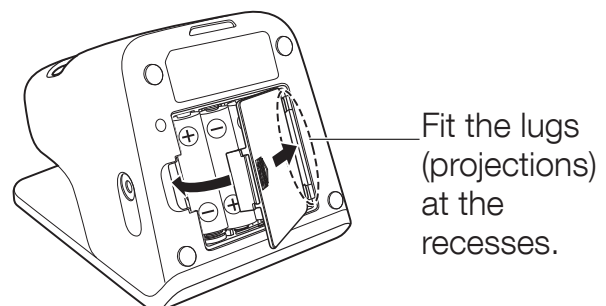
Fitting the lugs of the cover at the mating recesses of the battery compartment body, push the hook to close the cover.



REMOVING THE BATTERIES

- When the icon  is displayed or nothing appears in the display, replace the old batteries with four new ones. All four batteries should be changed at once.
- : The remaining capacity of the batteries is inadequate.
- Adjust the clock after changing the batteries.
- The data stored in the memory is not deleted by changing the batteries.
- Do not use rechargeable batteries.
- Do not use alkaline (LR6) and manganese (R6P) batteries together.
- Batteries included are for demonstration purposes only. Battery life may be shorter than specified.
- When disposing of used batteries, comply with governmental regulations or environmental public institution's rules that apply in your country/area.

USING AC ADAPTER (OPTION)

Using the optional dedicated AC adapter (model: AC-230CZ) for the CITIZEN blood pressure monitor (CH-456) allows you to measure your blood pressure without having to worry about the amount of remaining charge in the batteries.

Warning

The CH-456 and AC-230CZ should be used indoors in dry location.

1 Insert the AC adapter plug into the socket on the blood pressure monitor.

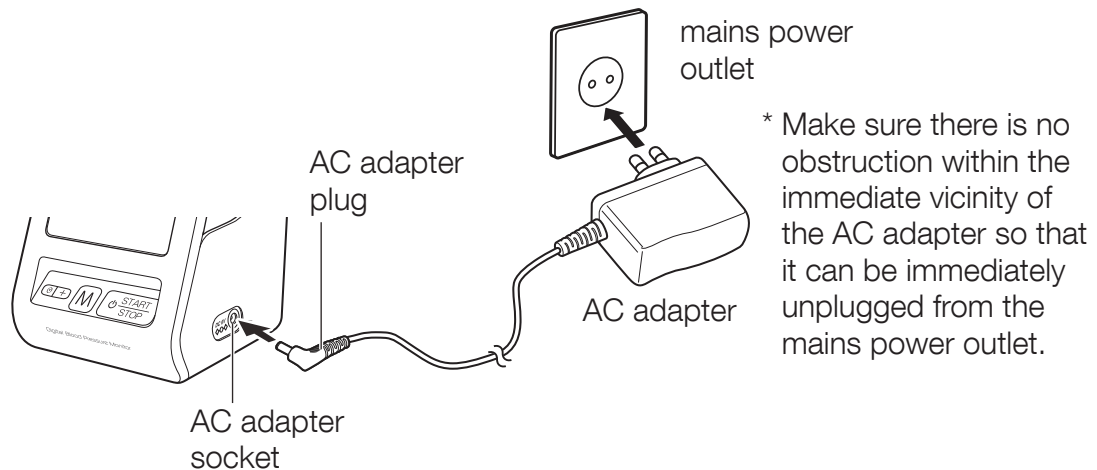

2 Plug the AC adapter into a mains power outlet.

- If you plan to use the AC adapter for an extended period of time, remove the batteries. If the batteries are left in the compartment, electrolyte may leak from the batteries and cause a fault in the blood pressure monitor.
- It is recommended that batteries are in the unit when using the AC adapter. If there are no batteries in the unit when the AC adapter is disconnected from either the power outlet or the unit itself, date and time settings will be lost.
- Plug the AC adapter into the socket, where you can easily plug off soon and safely in times of trouble.
- When disconnecting the AC adapter, unplug the AC adapter from the main power outlet, and then unplug the AC adapter plug from the socket on the blood pressure monitor.

The dedicated AC adapter (model: AC-230CZ) for the CH-456 is optional. The AC adapter is available from retailers stocking CITIZEN digital blood pressure monitors.

TIME ADJUSTMENT

Setting the clock enables measurements to be accurately recorded.

The monitor can record the date and time of measurement as well as the measurement results. Be sure to set the clock after inserting the batteries. Set the date first and then the time.

- * When you install the batteries for the first time, the monitor will display the clock setting screen. You do not need to perform step 1. Proceed to step 2. If you set the clock and change its setting, start from step 1.

1 Press and hold the Date/Time Set switch for approximately two seconds.

The “year” indicator blinks.

2 Press the Adjust switch to adjust the “year”.

Press  Adjust switch to increase the number by one. (The year can be adjusted in the range of 2015-2044.)

Press  Date/Time Set switch to confirm the setting. The “year” is set and the “month” indicator blinks.

- * You can fast-forward the numbers in display by pressing and holding  Adjust switch.



3 Press the Adjust switch to adjust the “month”.

Press  Adjust switch to increase the number by one.

Press  Date/Time Set switch to confirm the setting.

The “month” is set and the “day” indicator blinks.

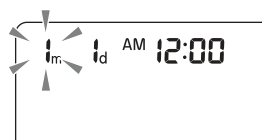

4 Press the Adjust switch to adjust the “day”.

Press  Adjust switch to increase the number by one.

Press  Date/Time Set switch to confirm the setting.

The “day” is set and the “hour” indicator blinks.



5 Press the Adjust switch to adjust the “hour”.

Press  Adjust switch to increase the number by one.

Press  Date/Time Set switch to confirm the setting.

The “hour” is set and the “minutes” indicator blinks.

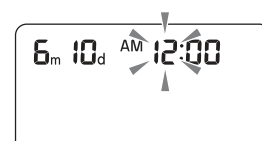

6 Press the Adjust switch to adjust the “minutes”.

Press  Adjust switch to increase the number by one.

Press  Date/Time Set switch with the time signal on the radio, etc. to confirm the setting.

The “minutes” are set and “12” (12-hour format) blinks.



7 Press the Adjust switch to adjust the “time format”.

The setting switches between 12-hour format (12H) and 24-hour format (24H) each time  Adjust switch is pressed.

Press  Date/Time Set switch to confirm the setting (12H or 24H).

When clock adjustment is completed, the set date and time appear briefly and then the display turns off.



MEASURING YOUR BLOOD PRESSURE

1 Plug the air hose connector into the main unit.

- Plug the air hose connector firmly into the air hose socket on the main unit, as illustrated.

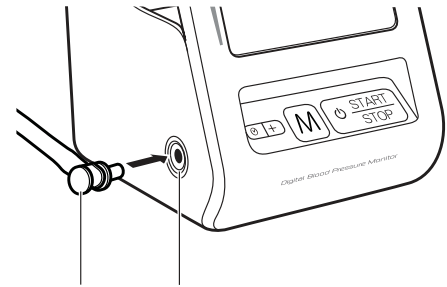

Air hose connector Air hose socket

2 ATTACHING THE CUFF

Before applying your blood pressure cuff, be sure you have selected the appropriate size cuff:

Cuff (model: SCN-003) fits arm circumference: 22-32 cm
[OPTION]

Large cuff (model: SCL-005) fits arm circumference: 32-42 cm

1 Unroll the cuff and thread the end through the metal hoop so that the side with the hook-and-loop fastener is on the outside.

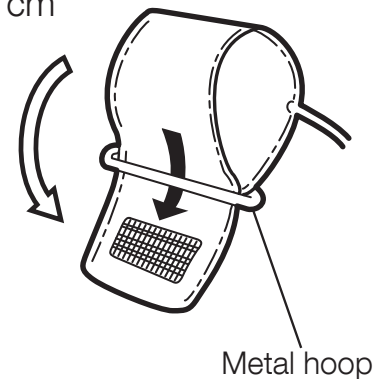

2 Put the cuff around your arm so that the blue marker comes to the palm side.

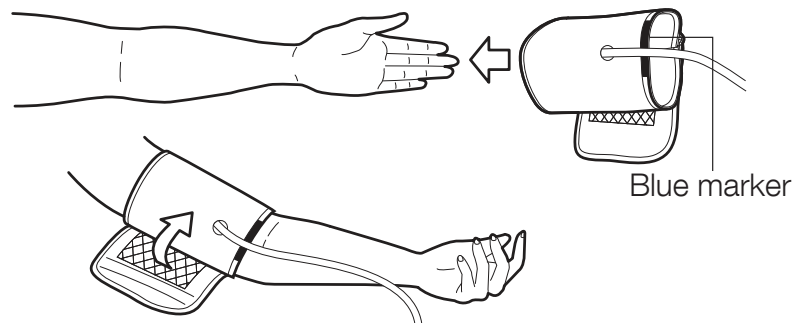

3 Adjust the position of the cuff so that the blue marker is located in the center of your arm and the hem of the cuff is 1-2 cm for Cuff / 2-3 cm for Large cuff above your elbow.

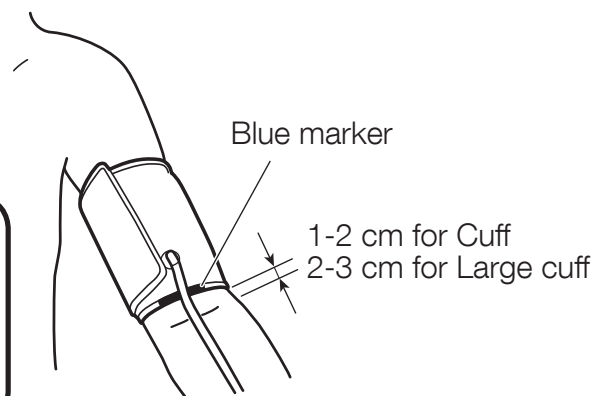

* The cuff should be put on the bare arm or over a light-weight underwear.

* If you wear a heavy-weight top, please remove it.

- 4** Pull the end of the cuff outwards so that the cuff is snug around your arm and then secure the end to the hook-and-loop fastener.

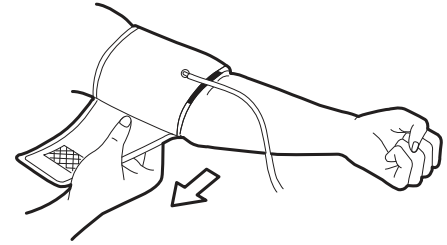

- 5** Place your arm on a table or the like, so that the center of the cuff comes to the height of your heart.

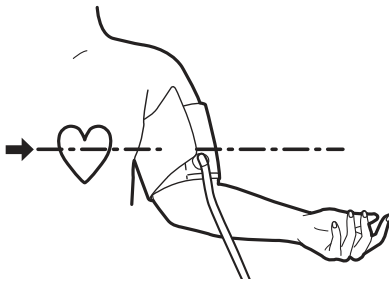
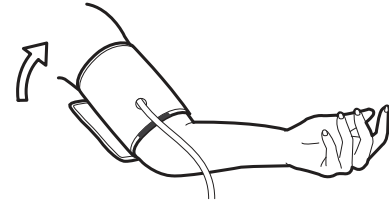

* Carefully place the cuff on your arm, taking care to use the correct tightness. The tightness is correct if you can readily slide a finger between the cuff and your arm.

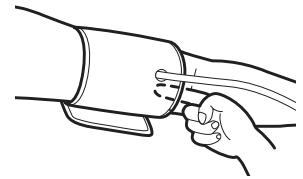

- 6** Relax your arm and lightly open your hand, with the palm upward.

- 3** Place the cuff at the height of the heart.

- 4** Press the “**⏻ START/STOP**” switch.

- All digits displayed is an initial display, indicating that the monitor is functioning normal.
- The cuff is pressurized automatically.
- * If the unit judges that pressurization is insufficient, it automatically repressurizes.

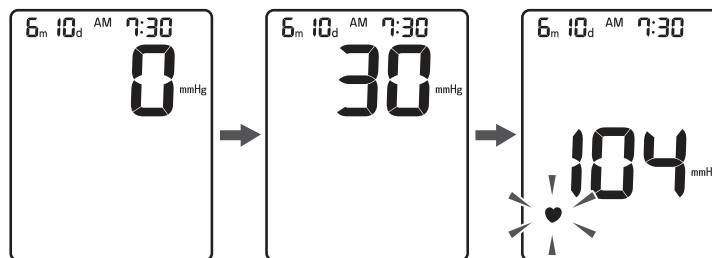

- * ♥ is displayed when a pulse is detected.
- * When you want to stop measurement, press the “**⏻ START/STOP**” switch. The cuff is deflated and measurement stops.

- * If the previous user had a high pressure setting, that high pressure will automatically be used for the current measurement.
- * If the pressurization value exceeds 280 mmHg, if pressurization feels abnormal, or if you want to stop the measurement process, press the “**⏻ START/STOP**” switch again. The cuff deflates, and the power turns off.

5 The measurement results are displayed.

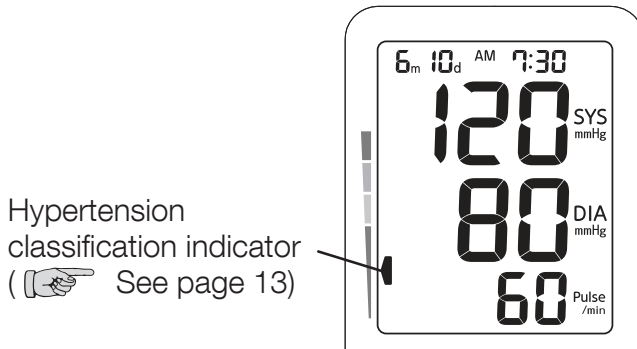

Hypertension classification indicator (See page 13)

- Once measurement is complete, the cuff deflates and the measurement results (systolic/diastolic blood pressure values, pulse) are displayed.
- * Provided there is no error in the measurement results, they are stored automatically.

6 Finishing measurement.

- Press the “ START/STOP” switch to turn the monitor off.
- After taking the blood pressure measurement, pressing the “ START/STOP” switch will turn the monitor off. However, if you do not press the switch, the monitor’s Auto OFF function will automatically turn the monitor off after 3 minute.

[Manual pressurization]

- If your systolic blood pressure is expected to exceed 200 mmHg, use Manual pressurization when taking a measurement.
 - Keep “ START/STOP” switch held pressed until the pressure value you want to stop pressurization is reached (approximately 40 mmHg higher than the Systolic blood pressure). You can stop pressurization by the unit by releasing the switch at the aforementioned value is reached.
- The upper pressure limit is 280 mmHg



The Body movement indicator is displayed on the measurement results display if you move your hand or arm during measurement, causing a substantial pressure change to be detected.

- If the Body movement indicator is displayed, measure your blood pressure again.



If an irregular heartbeat is detected during measurement, the Irregular heartbeat (IHB) indicator is displayed after measurement is completed. An irregular heart beat is defined as a heart beat that varies by $\pm 25\%$ from the middle of 5 heart beat intervals during the blood pressure measurement.

- Measurement may not be correct if your heartbeat fluctuates greatly during measurement. If the Irregular heartbeat (IHB) indicator is displayed, measure your blood pressure again.

Caution

If the Irregular heartbeat (IHB) indicator appears frequently, you are advised to consult a doctor about your health condition.

Hypertension Classification Indicator

The measured blood pressure value is displayed according to the WHO standards.

(👉 See page 2)

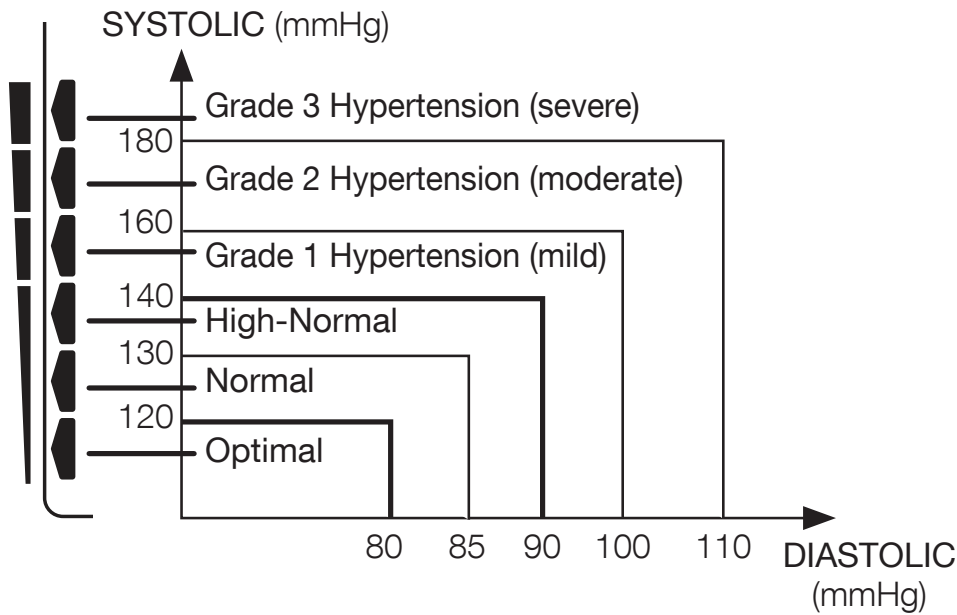

TIPS FOR OBTAINING ACCURATE MEASUREMENTS

Your blood pressure varies according to your posture, the time of day and a range of other factors. Ideally, you should measure your blood pressure in the same posture at the same time every day.

■ Taking measurements while sitting

* Be seated comfortably with your feet flat on the floor, and don't cross your legs.

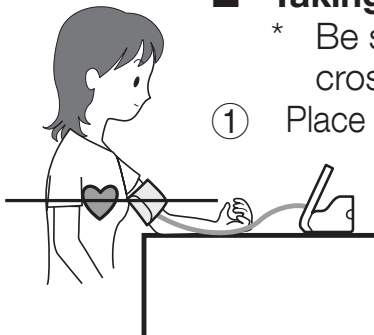

- ① Place your arm on a table or similar surface with your forearm extended.
- ② It is important to have the cuff level with your heart.
- ③ Open your hand slightly on the table so that your palm is facing up and your fingers are relaxed.
- ④ Do not move your body or talk while taking the measurement.

■ Measurement in a reclining posture

* Relax yourself to avoid placing pressure on the cuff.

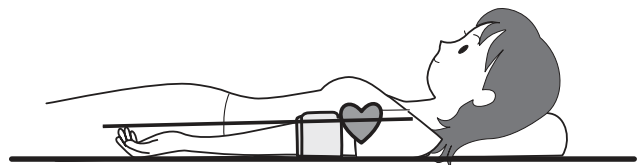

■ You may use your right arm to measure your blood pressure.

Blood pressure value is likely to differ by as much as 10 mmHg when measured on the right arm instead of the left (or vice-versa). Measure your blood pressure on the same arm each day.

CALLING UP THE DATA STORED IN MEMORY

90 measurement results can be stored in Memory.

The average value is calculated automatically to help you manage your daily health.

1 Press the **M** Memory switch once.

* Example of display when the **M** Memory switch is pressed.

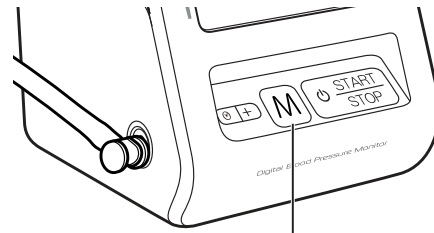

Memory switch

AVG indicating the average value appears at the bottom of the display. Then the average value, based on the last three measurements, is displayed.

* (**AVG** and the average value do not appear if there are two or fewer measurements stored in memory.)

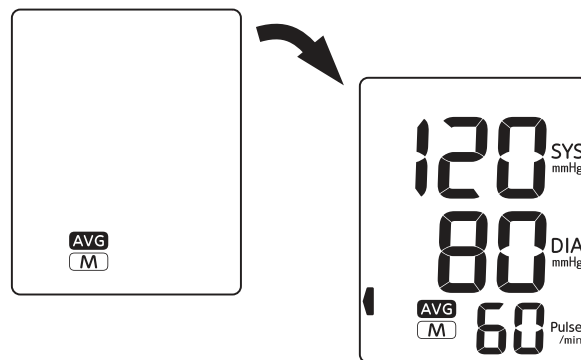

2 If you press the **M** Memory switch again, past measurement data are displayed.

Each time you press the switch, the measurement data are displayed in order from the most recent to the oldest.

* You can fast-forward the data numbers in display by pressing and holding the **M** Memory switch.

* Example of display when the **M** Memory switch is pressed.

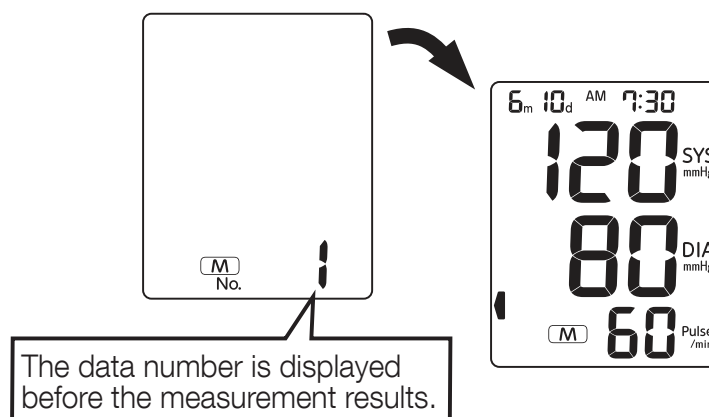

- The value stored in memory is numbered in the order of measurements. For example, when 90 sets of data are stored in memory, the data number 1 represents the latest data.

Data number: 1, 2, 3, 89, 90

↑
↑
 The latest data The earliest data

HOW TO DELETE THE DATA

- While pressing the **M** Memory switch, press and hold the “**START/STOP**” switch for more than 3 seconds.

All data stored in Memory will be deleted.

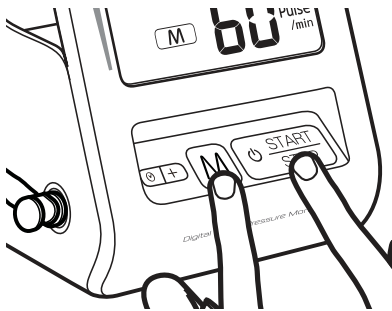

Press and hold for 3 seconds



Deleted

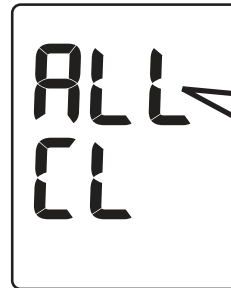

A message saying all the data have been deleted from the memory is displayed.

ABOUT “BLOOD PRESSURE”

What is blood pressure?

The heart is a pump that circulates blood throughout your body. Blood is pumped from the heart at a constant pressure into arteries. This pressure is called the arterial blood pressure and represents, in general terms, your blood pressure. Blood pressure is indicated by several kinds of pressures, including the systolic pressure that occurs when the heart pumps blood, and the diastolic pressure that occurs when blood returns to the heart.

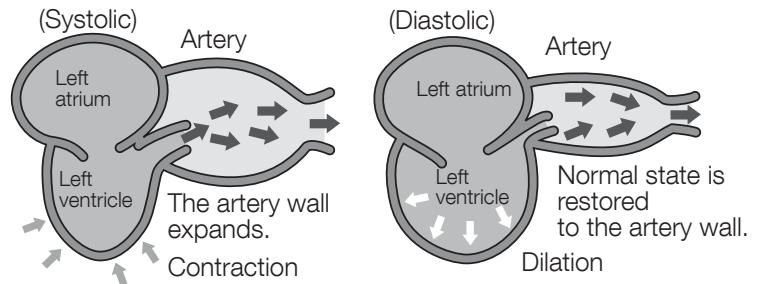

Your blood pressure changes all the time.

Your blood pressure differs according to your age, gender and a range of other factors. It is likely to be affected by your biorhythm during the day and by your posture, physical activities, mental activities, level of stress and even by the air temperature. The blood pressure of a healthy person generally varies within a day.

[Example of blood pressure variations within a day]

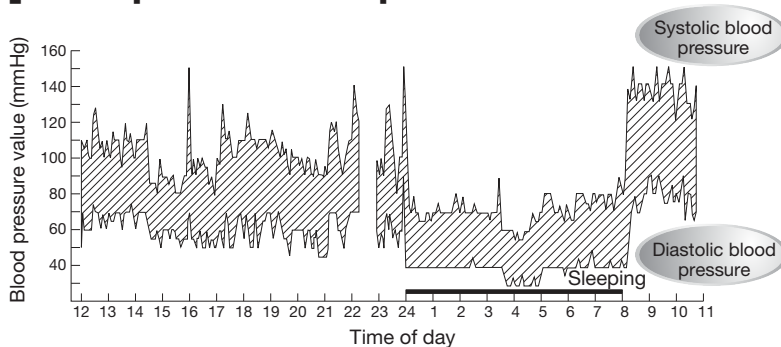

(Blood pressure values measured at five-minute intervals through the day)

● Bevan AT, Honour AJ, Stott FH. Clin Sci 1969;36:329–44.

BLOOD PRESSURE Q&A





- Q** Why is the blood pressure measured at home different from that measured by the physician or at a hospital?
- A** Your blood pressure may vary due to exercise, the ambient temperature or your mental state. When you have a physician or nurse measure your blood pressure, the pressure value is likely to be 10 to 20 mmHg higher than usual due to anxiety and/or stress. Knowing what affects your blood pressure helps you to better monitor your health.
- Q** Why does the blood pressure obtained vary with measurement?
- A** Our blood pressure is adjusted by automatic nerve function. Blood pressure differs with every heart beat. We are likely to think that our blood pressure is constant, but it varies if you take measurements in repetition. Blood pressure is susceptible to the time of day, such as morning and afternoon, season and atmospheric temperature. In addition, blood pressure is easily affected by mental stress or emotional ups and downs. It tends to increase when you feel tension or decrease when you are relaxed.
- Q** What is the benefit of measuring my blood pressure at home?
- A** Blood pressure measurements taken at home give reliable data as they can be taken when you are in a stable and relaxed condition. Physicians place considerable importance on blood pressure measurements taken at home. You should measure your blood pressure at the same time each day and record the variations in your blood pressure.



Always consult your physician for an interpretation of your blood pressure readings and to determine the proper treatment.

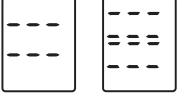

KEY TO DISPLAY ICONS

DISPLAY MARK	CONDITION/CAUSE	CORRECTIVE ACTION
	Appears when the cuff is attached too loose.	Attach the cuff properly and measure again. (See page 10 "ATTACHING THE CUFF")
	Appears when the cuff is not attached correctly and the pulse cannot be detected.	
	Appears when the pressure is 300mmHg or higher.	
	The pressure is 281 mmHg or higher.	If the pressure does not automatically decline during measurement, immediately press the "⏻ START/STOP" switch and turn the unit off. Take the measurement again.
	Appears when the batteries have run out.	Replace the batteries. (See page 7 "REMOVING THE BATTERIES".)

DISPLAY MARK	CONDITION/CAUSE	CORRECTIVE ACTION
	Appears when the pulse rate falls outside the measuring range (below 39 beats/min. or above 181 beats/min.)	Attach the cuff properly again. Take deep breaths to relax, and measure again. ( See page 13 "TIPS FOR OBTAINING ACCURATE MEASUREMENT".)
	The unit does not function properly.	Contact the store where it was purchased or your local service center. ( See page 17 "BEFORE REQUESTING REPAIRS OR TESTING".)

BEFORE REQUESTING REPAIRS OR TESTING

Make sure to check the following before sending your blood pressure monitor away to be tested or repaired.

Problem	Checks	Response
Display stays blank when you press the "ON START/STOP" switch.	Check whether the batteries are dead.	Replace all the batteries with new ones.
	Check whether the batteries are installed the right way round (\oplus and \ominus oriented correctly).	Load the batteries in the correct direction.
No measurements can be taken.	Check whether the measurement icon  is displayed.	Attach the cuff properly.
	Check whether the cuff is attached correctly.	
	Did you stay calm during measurement?	Measure your blood pressure again, making sure to remain still.
	Note that blood pressure measurement may not be possible for someone with an extremely weak pulse or cardiac arrhythmia (irregular pulse).	
Your blood pressure readings are abnormally high or low compared with those taken in hospital.		 See page 16.
Other phenomena		Remove the batteries from the unit and change them with new ones.

* If you want to dispose this product, do not mix with general household waste. There is a separate collection systems for used electronics products in accordance with legislation.

- CITIZEN is a registered trademark of Citizen Holdings Co., Japan.
 - Design and Specification are subject to change without notice.
-

CITIZEN SYSTEMS JAPAN CO., LTD.

6-1-12, Tanashi-cho, Nishi-Tokyo-shi,
Tokyo 188-8511, Japan

E-mail: sales-oe@systems.citizen.co.jp

<http://www.citizen-systems.co.jp/>